

### SAIL AREA ALLOWANCE

WIND REGION/ TERRAIN CATEGORY	A2	A3	B2	B3	C2	C3
SAIL AREA (m <sup>2</sup> )	0.43	0.55	0.21	0.29	0.08	0.17

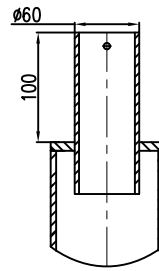

SPIGOT DETAIL

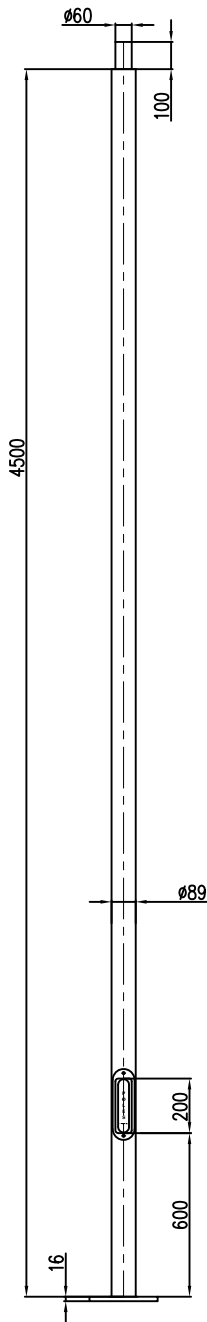
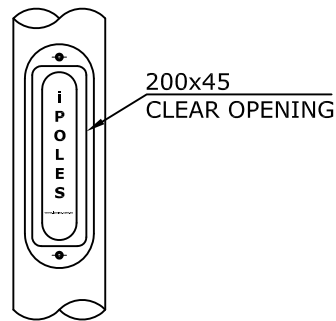

DOOR DETAIL

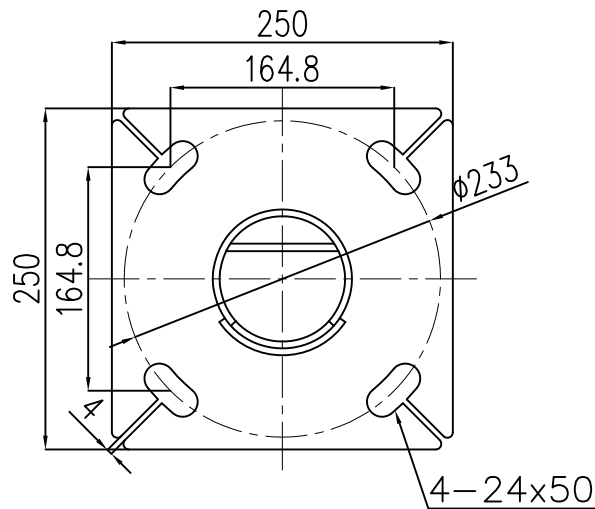

BASEPLATE FOR M20X4@233 PCD RAGBOLTS

**NOTES:**

1. POLES DESIGNED IN ACCORDANCE WITH BCA, AS4100:1998, AS/NZS 1170.2 2002, AS 1798:1992, AS/NZS 4676:2000, AS/NZS 4677:2000.
2. HOT ROLLED STEEL FLAT PRODUCTS TO CONFORM TO AS 1594
3. HOT ROLLED STEEL BARS AND SECTIONS TO CONFORM TO AS 3679
4. WELDING OF STEEL STRUCTURES TO CONFORM TO AS/NZS 1554.1:2004
5. ALL STEEL ITEMS TO BE FULLY HOT DIP GALVANISED AFTER FABRICATION TO AS/NZS 4680:2006.
6. HOT ROLLED STEEL PLATES TO CONFORM TO AS3678.
7. ALL DIMENSION ARE IN MILLIMETRES

Customer/Project

Title

4.5m 90mm OD Pipe pole c/w access  
Door and a 60mm OD Spigot

Catalogue.no

P90-45-60

LAST UPDATED

14/04/14

Drawn by  
Checked by

LQ  
J.RIAD

drg. no.

P90-45-60-GA



**INTERNATIONAL  
POLES**

5 Rose St,  
CAMPBELLTOWN NSW, 2560.  
PH: (02)4627 6500  
FAX: (02)4627 6533  
EMAIL: Eng@ipoles.com.au